

### EXP Expanded Louver

For DUX Two Way Weather Protection

Chemical Gas Suppression  
Pressure Relief

Two Way Venting  
Building Blast Protection

### EXP Expanded Louver

Steel Construction

Zero FVA Restriction

Internal Storm Shield

Easy Installation



## EXP EXPANDED LOUVER

### Weather Protection for DUX Vents

*Designed specifically to compliment FVA of DUX Two Way Vents.*

The EXP Expanded Louver unit is used with AmVentco's DUX range of pressure relief dampers in halocarbon installations. It has been specifically designed to provide a Free Vent Area (FVA) matching that of DUX while providing the weather protection essential for two-way vents in exterior walls.

The louver blades are assembled into a custom-designed 'Expanded Louver Box' – hence EXP – which increases the effective FVA to match the 85% FVA of the DUX. *(Typically fixed louvers only achieve 50% FVA maximum)*

The EXP 14 & 22 are fitted with a new storm shield which is a carefully designed mesh that prevents storm blown rain and insects entering behind the unit whilst having zero effect on any blast protection.

### PRODUCT DETAILS



#### DUX Weather Protection

Designed for DUX Two Way pressure relief damper weather protection. (for exterior wall use)

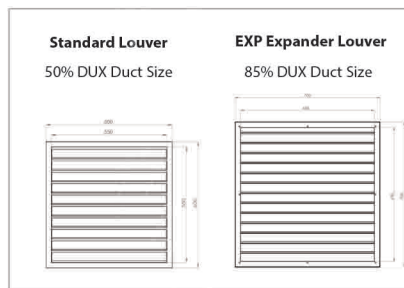

#### No Vent Area Restriction

'Expander Louver' design matches the FVA of the DUX Two Way for maximum pressure venting efficiency.



#### Easy Installation

Steel construction. Surface mount easy installation. Fitted with 'Storm shield mesh' for rain ingress and insect protection.

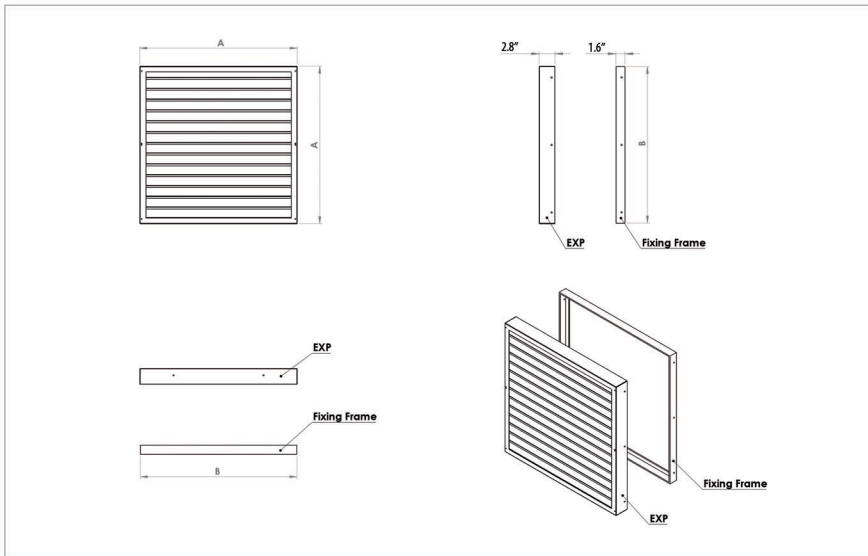

## TECHNICAL DATA

Product Code	Dim	EXP 14	EXP 22
FVA NEGATIVE		0.83 ft <sup>2</sup>	2.28 ft <sup>2</sup>
FVA POSITIVE		0.83 ft <sup>2</sup>	2.28 ft <sup>2</sup>
EXP	A A	19.8" x 19.8"	27.5" x 25.5"
FIXING FRAME	B B	19.5" x 19.5"	27.3" x 27.3"
WEIGHT		16 lbs	27 lbs

## EXTERNAL WEATHER PROTECTION

*For use with DUX Two Way Vents.*

The EXP has been specially designed to complement the superior performance of the DUX Two Way pressure relief damper.

When used in combination with the DUX it works to maintain the same FVA as the DUX and so offers no restriction on performance.

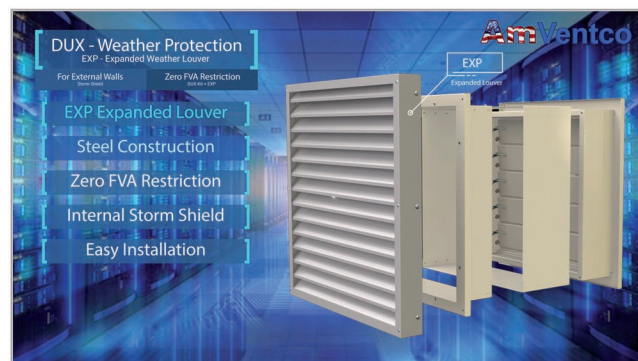

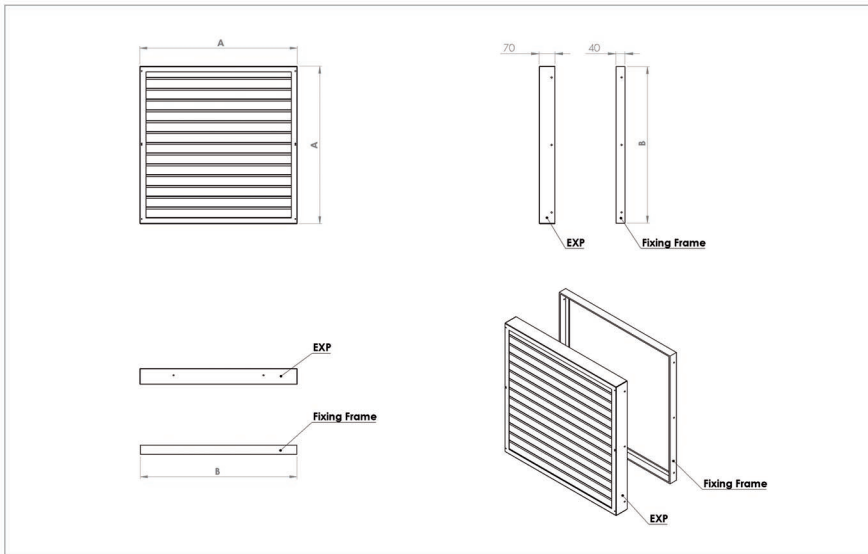

## TECHNICAL DATA

Product Code	Dim	EXP 14	EXP 22
FVA NEGATIVE		0.076m <sup>2</sup>	0.212m <sup>2</sup>
FVA POSITIVE		0.076m <sup>2</sup>	0.212m <sup>2</sup>
EXP	A A	500 x 500mm	700 x 700mm
FIXING FRAME	B B	495 x 495mm	695 x 695mm
WEIGHT		7kg	12kg

## EXTERNAL WEATHER PROTECTION

*For use with DUX Two Way Vents.*

The EXP has been specially designed to complement the superior performance of the DUX Two Way pressure relief damper.

When used in combination with the DUX it works to maintain the same FVA as the DUX and so offers no restriction on performance.

