



DUX TWO WAY For Chemical Gas Supression Systems

The world's first and only Double Action pressure relief damper (pat App).

Superior to single top pivot solutions, the DUX is a compact, extremely robust and efficient two way pressure relief damper, ideal for chemical gases. The DUX is the world's first 'Double Action' two way pressure relief damper for halo-carbon gases (pat applied) and provides a level of performance not otherwise available for this application.

AmVentco's top weighted, offset pivoted, aerofoil style blades have the best available efficiency, reaction time and all out performance. The double pivot design with interlocking adjacent blades offers superior fire protection with low overall leakage and unique pressure relief efficiency.

PRODUCT DETAILS



4 Hour Fire Rated

4 hours to BS EN 1363-1 2012
2 Hours to UL-555



Live Discharge Tested

Built to BRE live discharge tests standards 2008.
Suitable for all chemical gasses.
HFC-125/HFC-227ea/FK-5-1-12

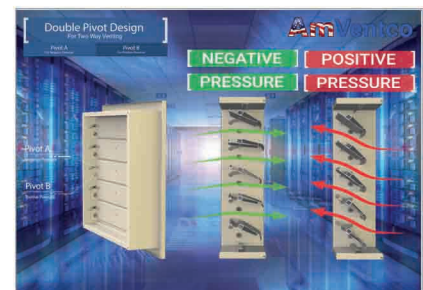

Two Way Venting

Unique Double Pivot System for two way venting and presure relief.
(pat app)

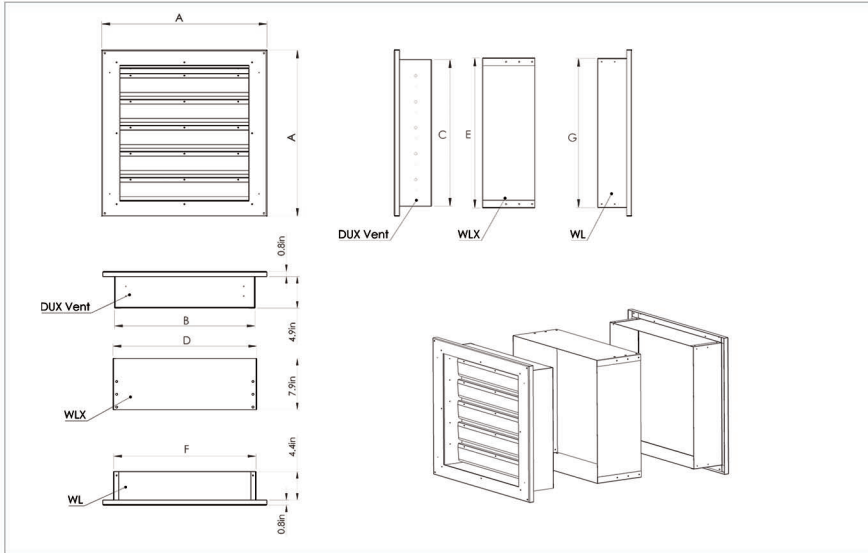

Standard kit fits walls from 4" to 15" thick.

DUX Kit includes :

- DUX vent
- WL Wall Liner
- WLX Wall Liner Extension
- Fixing Kit
- Fitting Instructions

Full open pressure 120-160pa
(from static fan test)

3 year guarantee

TECHNICAL DATA

Product Code	Dim	DUX 14	DUX 22
FVA NEGATIVE		0.83ft2	2.28ft2
FVA POSITIVE		0.51ft2	1.38m2ft2
DUX VENT FLANGE	A A	17.0" x 17.0"	25.0" x 25.0"
DUX VENT	B C	13.8" x 14.4"	21.6" x 22.3"
WLX	D E	14.2" x 14.9"	22.0" x 22.8"
WL	F G	14.0" x 14.8"	21.9" x 22.6"
WEIGHT		33 lbs	55 lbs
WALL CUTOUT SIZE	W x H	14 3/8" x 15"	22 1/8" x 22 7/8"

EXTERNAL WALL INSTALLATION

An EXP (Expanded Louver Unit) should be used for installation on exterior walls.

Due to the maximum FVA of a fixed louver being only 50%, the EXP compensates for this by being a larger 'expanded louver' unit. When used in combination with the DUX it works to maintain the same FVA as the DUX and so offers no restriction on performance.



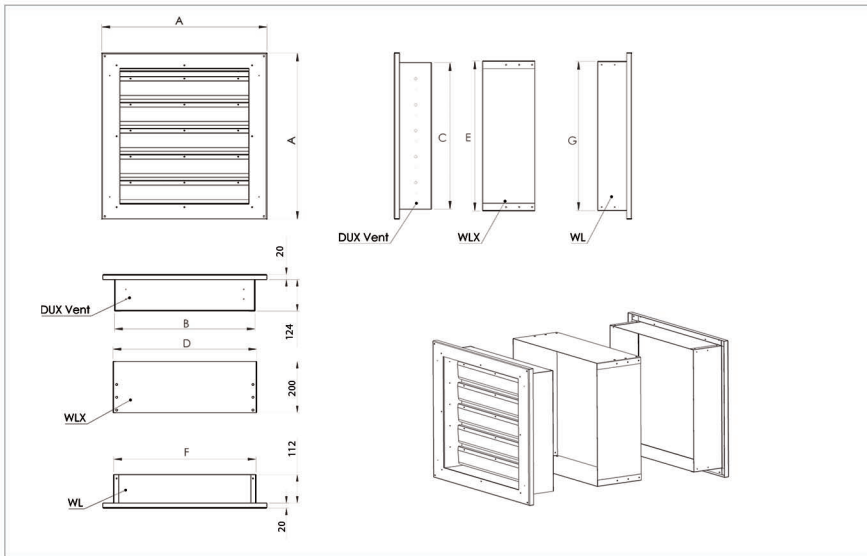

Standard kit fits walls from 100mm to 380mm thick.

DUX Kit includes :

- DUX vent
- WL Wall Liner
- WLX Wall Liner Extension
- Fixing Kit
- Fitting Instructions

Full open pressure 120-160pa
(from static fan test)

3 year guarantee

TECHNICAL DATA

Product Code	Dim	DUX 14	DUX 22
FVA NEGATIVE		0.076m ²	0.216m ²
FVA POSITIVE		0.047m ²	0.128m ²
DUX VENT FLANGE	A A	430 x 430mm	630 x 630mm
DUX VENT	B C	350 x 365mm	500 x 565mm
WLX	D E	361 x 378mm	561 x 578mm
WL	F G	356 x 375mm	556 x 575mm
WEIGHT		15kg	25kg
WALL CUTOUT SIZE	W x H	365 x 380mm	560 x 580mm

EXTERNAL WALL INSTALLATION

An EXP (Expanded Louver Unit) should be used for installation on exterior walls.

Due to the maximum FVA of a fixed louver being only 50%, the EXP compensates for this by being a larger 'expanded louver' unit. When used in combination with the DUX it works to maintain the same FVA as the DUX and so offers no restriction on performance.

